



TAKE A CLOSER LOOK CAT[®] UNDERCARRIAGE

**OPTIONS TO MATCH YOUR APPLICATION
AND UNDERFOOT CONDITIONS**

MORE THAN THE RIGHT CHOICE... THE BEST CHOICE

Every customer, every job, every machine—every choice you make has an impact on your business. Your success rides on choosing the equipment and tools that deliver the best productivity, durability, and value for your applications.

We offer more undercarriage options for your Cat® machines than any other manufacturer because we know that the more precisely you match iron to application, the more effective and efficient your work will be. Whether you're looking for the lowest upfront cost, longer wear life or lower operating costs per hour, we have the right undercarriage solution for your business.

Every Cat Undercarriage is designed by Caterpillar engineers and built to exacting specifications based on the real-world experience of our customers. And our undercarriage systems come with industry-leading warranties, so when you choose a Cat Undercarriage you know it's not just the right choice, it's the best choice.

LET'S DO THE WORK.™



CAT®

UNDERCARRIAGE SELECTION MATTERS

One of the most important factors in helping you achieve the lowest owning & operating costs and maximizing equipment uptime is matching the right undercarriage option to your specific machine model and work application.

Your Cat dealer has the knowledge and tools to help you choose the best undercarriage configuration for your equipment and your job. When consulting with you, dealers use these tools and take key factors into account to recommend proven Cat components to help you get the job done.

	KEY SELECTION FACTORS TO CONSIDER
TRACK FRAME CONFIGURATION	Standard, Extended (XL), Extra Wide (XW), Low Ground Pressure (LGP)
WIDTH OF TRACK SHOES	Narrow, intermediate or wide shoes ranging from 15"-38" (a metric conversion)
TYPE OF TRACK SHOE	Extreme Service (ES), Moderate Service (MS), Super Extreme Service (SES), Clipped, Center Hole
BLADE TYPE	Variable-pitch Power Angle/Tilt (VPAT), Semi-Universal (SU), Angle, Straight
REAR ATTACHMENT	Winch, Ripper, Counterweight, Drawbar
OTHER ATTACHMENTS	Sweeps, Window Guarding, Additional Blade Wear Material
UNDERFOOT CONDITIONS	Light, Moderate or Severe Abrasion and Impact
TERRAIN	Side Slopes, Ground Objects and V-ditching
PACKING CONDITIONS	Operating in extrusive materials, which can usually be squeezed out from between track parts when wet, e.g., clay soils Operating in non-extrusive materials, which can't be extruded from the link windows and track shoe center holes of most undercarriage tracks, e.g., branches



UNDERCARRIAGE APPLICATION GUIDE

Life/Impact Matrix

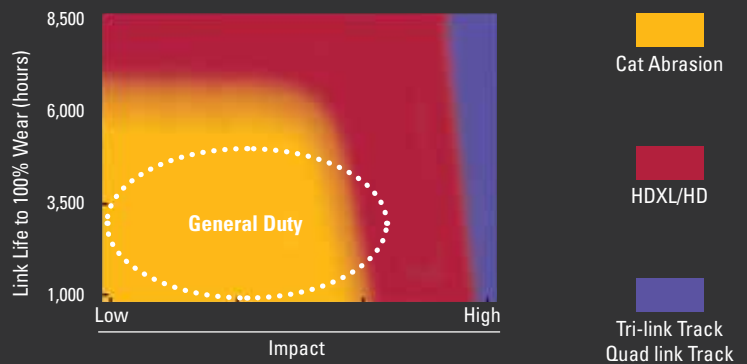

GENERAL DUTY

Although General Duty covers a wide range of applications, it is designed for low-to-moderate impact conditions. There are multiple factors to consider when making an undercarriage selection including: ownership period, hours of machine usage, purchase price and cost-per-hour. Your Cat dealer can help you select the best undercarriage for your application and job requirements.

COST-PER-HOUR ANALYSIS

Dealers use undercarriage tools to run cost-per-hour scenarios to help determine which undercarriage option is the best fit for your business requirements. So be sure to consult with your Cat dealer to select the right undercarriage solution for the job—and your bottom line.

FIND THE RIGHT UNDERCARRIAGE

We've been helping customers find the best undercarriage for their job requirements for over a century—longer than anyone else in the business. You get the benefits of that experience.



WHAT IS THE BEST FIT FOR YOU?

Your work environment is the most important element in selecting undercarriage to meet the demands of your business and your budget. Answering the following questions will help you choose the right Cat Undercarriage for your business:

- How long will I own this machine?
- How many hours a week will I be using this machine?
- What are my typical ground/soil conditions?
- What are my impact conditions?
- What attachments are on my track-type tractor?
- What are the grades/slopes on my job site?

The more precisely you define these parameters, the more effective your choice will be.

		CAT ABRASION	HEAVY DUTY	HDXL	GENERAL DUTY	TRI/QUAD
TRACK LOADER COMPATIBILITY	953	•	•		•	
	963	•	•		•	
	973		•		•	
TRACK-TYPE TRACTOR COMPATIBILITY	D4 (D6K)	•	•			
	D5 (D6M, D6N)	•		•	•	
	D6 (D6H, D6R, D6T)	•		•	•	•
	D7			•	•	
	D8		•	•	•	



CAT ABRASION™ UNDERCARRIAGE

THE LEADER IN LOWEST COST PER HOUR

Cat Abrasion is built on proven Cat Rotating Bushing technology that extends undercarriage wear life. Combined with an advanced proprietary cartridge design that dramatically improves sealability, Cat Abrasion delivers the lowest cost per hour in high-abrasion, low-to-medium impact applications.



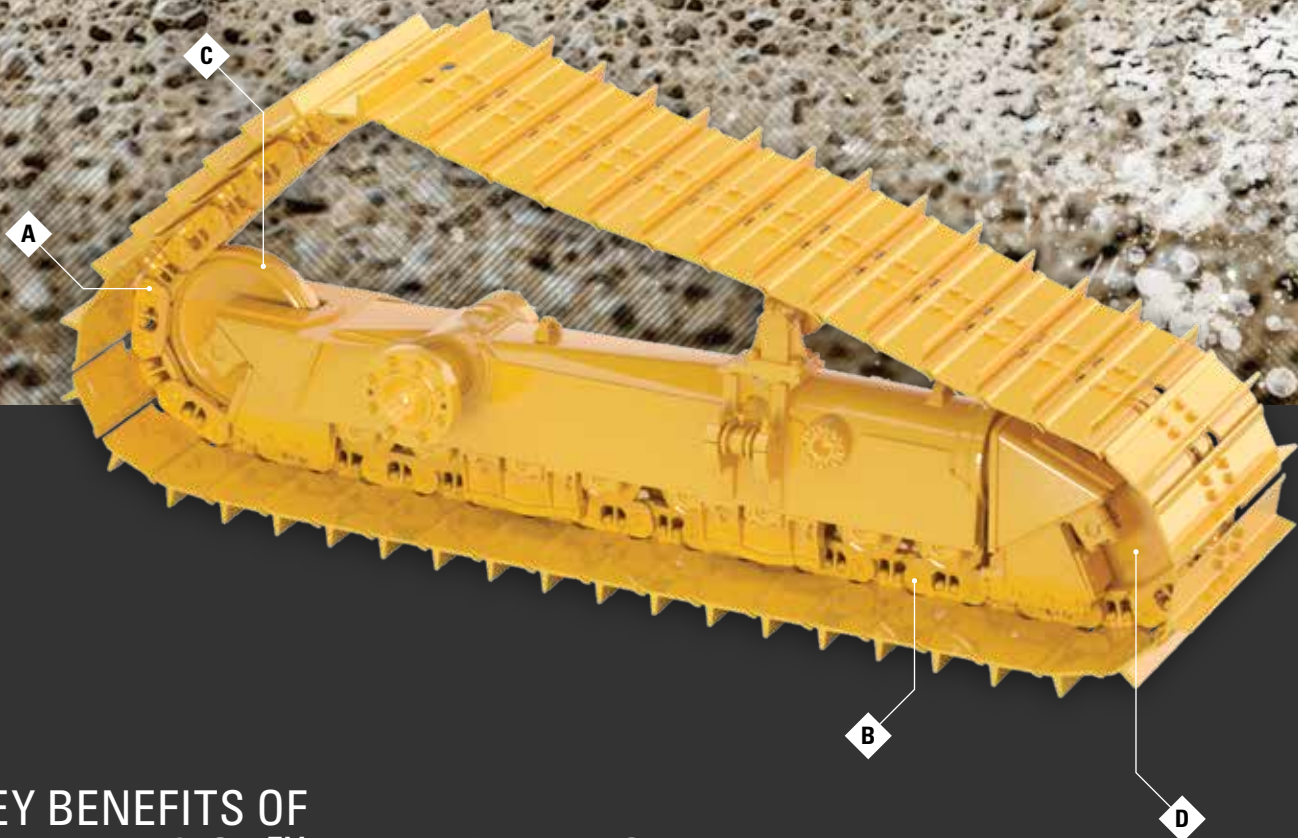

KEY BENEFITS OF CAT ABRASION™ UNDERCARRIAGE

- New Extended Life (XL) coating reduces end grooving, corrosion and seal lip wear
- New track seal and load ring design reduces packing and oil loss in freeze/thaw conditions
- Refined seal bore geometry enhances material flow through the seal area
- Tougher thrust ring material resists chipping and cracking

LESS MAINTENANCE

Eliminates need for bushing turns in abrasive applications means less time in the shop for your machine

A

B

LOWER COSTS

Better sealability means less maintenance and reduced costs over the lifecycle of your machine

EXTENDED WEAR LIFE

Patented relieved tread idler design extends life up to 2x longer compared to traditional idlers

C

D

SMOOTHER RIDE

Eliminates contact between idlers and link rails, providing a smoother ride for operators

Top that off with industry-best undercarriage assurance of up to 6,000 hours on all components and world-class dealer support, and your choices are even better.

HEAVY DUTY EXTENDED LIFE UNDERCARRIAGE WITH DURALINK™ (HDXL)

LEADER IN LOWERING O&O COSTS

Take our Heavy Duty Undercarriage to the next level with exceptional wear life and lower cost per hour than competitive brands, with proven 20-40% longer life. Designed for maximum durability, our HDXL systems are engineered with additional wear material, heat treatment, and increased sealability after bushing turns. Cat DuraLink™ delivers a stronger link with superior pin retention technology. Extend your undercarriage life in aggressive, high-impact applications such as:

- Logging/reforestation
- Side-sloping work
- Rocky conditions and uneven terrain



HDXL utilizes Positive Pin Retention 2 (PPR2) technology to extend undercarriage life. PPR2 mechanically locks the link to the pin to resist pin walking and link cracking for reliable sealing and track life. That means more uptime for your machine – and more productivity for your business.

Enhancements include:

- Upgraded link eliminates cracking and spalling
- Larger bolt improves shoe retention
- Increased pin and bushing retention extends wear life
- Better pin retention, longer seal life

POSITIVE PIN RETENTION 2 (PPR2)

- Resists end-play generation and link movement on the pin
- Tightly controls seal motion for long internal pin/bushing wear life
- Resists fatigue and crack formation with stronger track links

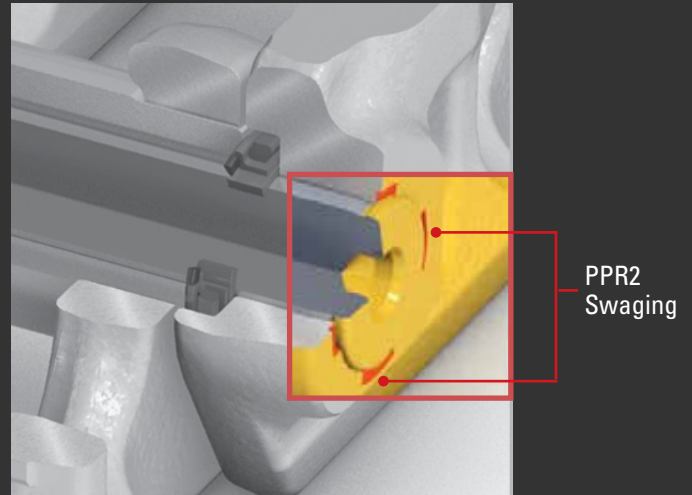

The HDXL patented system for the D8 combines larger diameter bushing, track roller, and sprocket segments to create a link assembly with more wear material, improved life, and innovative enhancements that keep your machine working – and making money.

Enhancements include:

- New crowned link prevents link scalloping
- Improved sealing system eliminates dry joint issues
- Increased bushing and link wear material extends wear life
- Redesigned nut seat window eliminates cracking
- Scallop design wear surface eliminates vibration

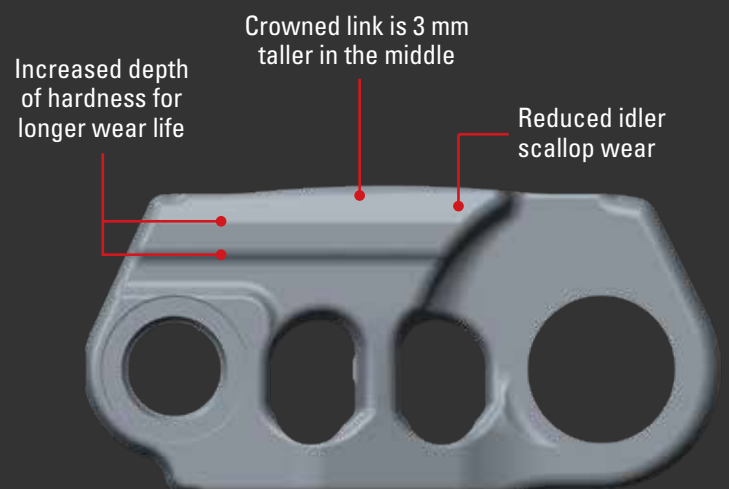

**INDUSTRY-LEADING UNDERCARRIAGE ASSURANCE
WITH 4 YEARS/5,000 HOURS OF PROTECTION**

Patented Caterpillar Design

HEAVY DUTY UNDERCARRIAGE

TOUGH TRACK FOR TOUGH JOBS

Specifically engineered to match the requirements of medium-size machines with an elevated sprocket operating in demanding work environments.

In most tough underfoot conditions, Heavy Duty track can extend your undercarriage system life up to 20 percent more than Cat General Duty, with the greatest benefits realized in aggressive, high-impact applications such as:

- Logging/reforestation
- Side-sloping work
- Rocky conditions
- Any uneven terrain with wide track shoes (specifically Low Ground Pressure (LGP) machines)

HEAVY DUTY TRACK COMPARED TO GENERAL DUTY TRACK

Component	Benefit
LINKS	<ul style="list-style-type: none"> • Greater bushing retention • Deeper heat-treat • Increased strength
BUSHING	<ul style="list-style-type: none"> • Increased Retention
PIN	<ul style="list-style-type: none"> • Increased Retention

Results may vary based upon application.

GENERAL DUTY TRACK

PERFORMANCE YOU CAN COUNT ON

We recommend General Duty Undercarriage for your low-to-moderate impact applications where the elevated performance of the Cat Heavy Duty Undercarriage is not needed.

- While General Duty track is built to different specifications than Heavy Duty, we design it so General Duty and Heavy Duty components are interchangeable. That eliminates any need for retrofitting and keeps your machine downtime to a minimum. And Cat Heavy Duty shoes can be installed on General Duty link assemblies, making them more flexible to meet your needs.
- General Duty also offers a track shoe options, so you can choose the right track shoe for your application. For most General Duty undercarriage applications, moderate service shoes offer optimal performance and wear life.
- Your Cat dealer has General Duty parts stocked and available for fast turnaround, keeping you and your machine working.
- Industry-Leading Undercarriage Assurance With 4 Years/3,000 Hours



CAT TRI-LINK & QUAD-LINK TRACK

DESIGNED FOR THE EXTREME

Specifically engineered to match the requirements of medium-size machines with an elevated sprocket operating in demanding work environments.

Caterpillar developed Tri-Link track and Quad-Link track as undercarriage solution options for customers working in the most severe impact conditions. These unique designs improve link assembly strength by bolting on additional outrigger chains, making them the right choice for logging (skidding), stumping, and taking on work in rocky terrains or any application where shoe deflection is high. Tri-Link track adds one outrigger chain to the outer ends of the track shoes and Quad-Link track adds two, greatly improving sealability and structural performance.

While using Tri-Link track or Quad-Link track may at first seem more expensive, these tough tracks typically result in lower undercarriage cost-per-hour because they were designed specifically for extreme conditions and provide better load distribution, improved lubricated joint life (fewer dry joints), and greater system reliability.

NOTE: Tri-Link track and Quad-Link track are available only with the Heavy Duty track option.

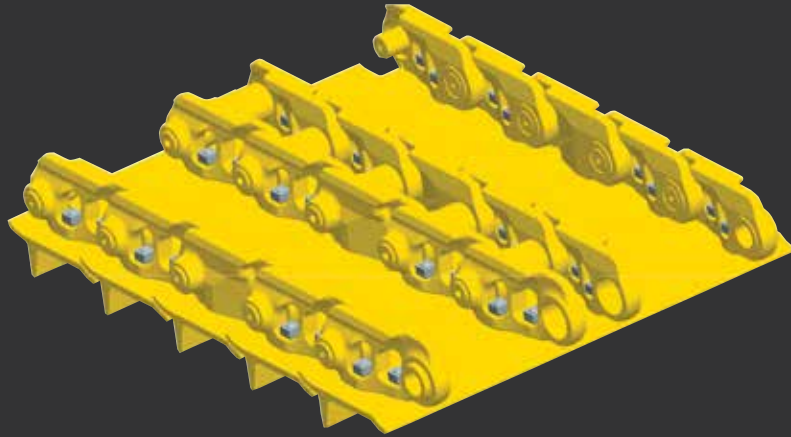

POSITIVE PIN RETENTION (PPR) TRACK

MAXIMUM TRACK LIFE

PPR track features specially machined links and pins that allow for the use of a metal retaining ring. This ring is pressed into the groove between the pin and link, locking the joint to a predetermined factory end-play specification.

- Prevents end-play generation (the outward movement of the links on the pin)
- Ensures oil retention in high-impact conditions

This exclusive Caterpillar design is recommended for high-impact loading applications like mining, heavy construction, demolition, and waste disposal. You could also benefit from PPR track if your machines are equipped with wider shoes, Extreme Service shoes, or Super Extreme Service shoes.

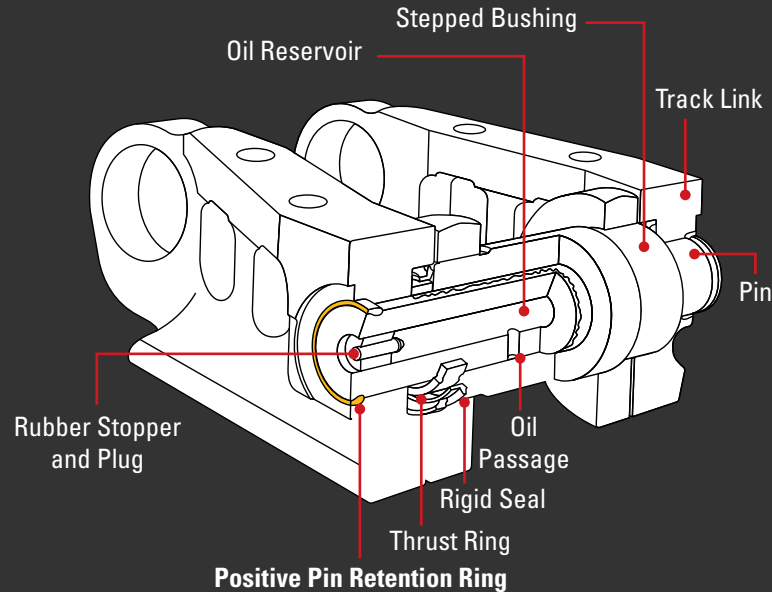

COMPREHENSIVE SUPPORT

To help you get the most from your Cat Undercarriage, Caterpillar and Cat dealers remain dedicated to providing you with global service and support for all undercarriage configuration options from advanced diagnostics to worldwide parts delivery.



UNDERCARRIAGE AND WEAR LIFE ASSURANCE PROGRAMS

We're committed to helping you keep your machines working. And our Undercarriage Assurance Programs provide you the lowest cost-per-hour undercarriage systems and support beyond standard new machine or parts warranties.

They cover all major moving undercarriage components on Cat Track-Type tractors, Track-Type loaders and Track-Type hydraulic excavators. See your Cat dealer for full details about coverage for specific undercarriage configuration options.

	GENERAL DUTY	HEAVY-DUTY EXTENDED LIFE (HDXL)	CAT ABRASION
COVERAGE IN YEARS	4	4	4
COVERAGE IN HOURS	3,000	5,000	6,000
COVERAGE IN PERCENT WORN	100%	100%	100%

Stipulations Apply

CUSTOM TRACK SERVICE (CTS)

An improperly managed undercarriage can cause downtime and account for more than half of machine maintenance costs. That's why we use the most advanced diagnostic equipment available to provide Custom Track Service (CTS) for maintaining your undercarriage system.

With CTS, we can accurately monitor undercarriage performance and predict wear rates so you can evaluate service options, plan maintenance, and fit downtime into your schedule. And because CTS analysis can be completed on the job site, you can make informed decisions that keep your operating costs as low as possible, without sacrificing uptime.

WORLDWIDE PARTS AVAILABILITY

Our industry-standard parts distribution network makes most new parts available to you anywhere in the world, usually within 24 hours.

CONSULT WITH YOUR CAT DEALER TODAY

Your Cat dealer has the undercarriage expertise and selection tools to help you make the best decisions for your machine, application, and owning and operating needs.

